



Custom-Me

INSTABILELAB
ART IN THE WALLPAPER



Moderna LLC
www.Moderna.design
267 Fifth Avenue #800
New York, NY 10016
917-583-3330
contact@moderna.design

Custom-**Me**

Custom-Me

Custom-Me è la creazione di un'atmosfera. Non solo un progetto ma un modo di progettare, non solo una proposta originale ma un modo di guardare l'ambiente che va oltre gli elementi strutturali e i complementi d'arredo.

Tutto nasce dalla carta da parati e si allarga coinvolgendo complementi e tessuti, interamente personalizzabili con le grafiche della collezione. Instabilelab propone 6 diversi ambienti, dal domestico al contract agli spazi pubblici per presentare un nuovo modo di arredare.

Custom-Me is the creation of an atmosphere. Not just a project but a way of designing, not just an original proposal but a way of looking at the surrounding that goes beyond structural elements and furnishing accessories. Everything comes from wallpaper and widens by incorporating such piece of furniture and fabrics, entirely customizable with the graphics of the collection. Instabilelab presents 6 different locations, from domestic to contract to public spaces to introduce a new way of thinking about the surrounding.

index

LOCATIONS & SOLUTIONS

| | |
|-----------------------|----|
| CUSTOM LIVING 01 | 0 |
| CUSTOM LIVING 02 | 7 |
| CUSTOM NIGHT 01 | 1 |
| CUSTOM NIGHT 02 | 3 |
| CUSTOM MEETING 01 | 1 |
| CUSTOM MEETING 02 | 9 |
| | 2 |
| | 5 |
| | 3 |
| CUSTOM-ME PRODUCTS | 1 |
| | 3 |
| HOLLY bed | 49 |
| COMPO-bed | 53 |
| CARPETS | 57 |
| MOQUETTE | 61 |
| CORTINAS curtains | 63 |
| TEXTILE | 67 |
| BEAUTIFUL LIGHT lamps | 71 |
| CUBIKA armchair | 73 |
| ANNABEL armchair | 75 |
| RELAXIA pouf | 77 |

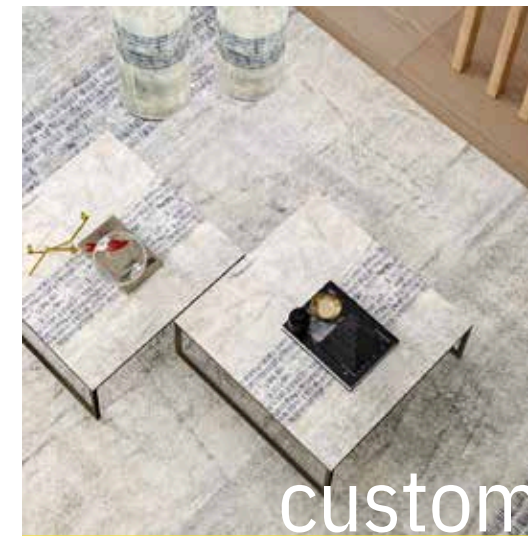

custom living

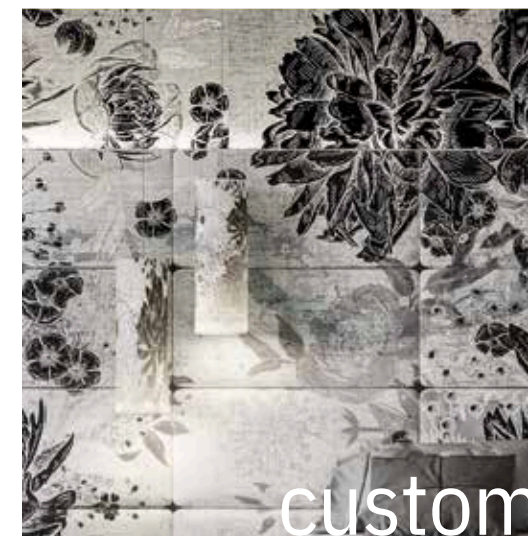

custom night

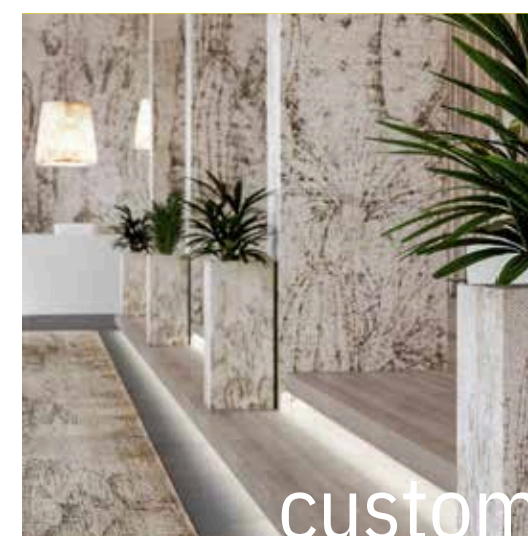

custom meeting





CUSTOMLIVING01

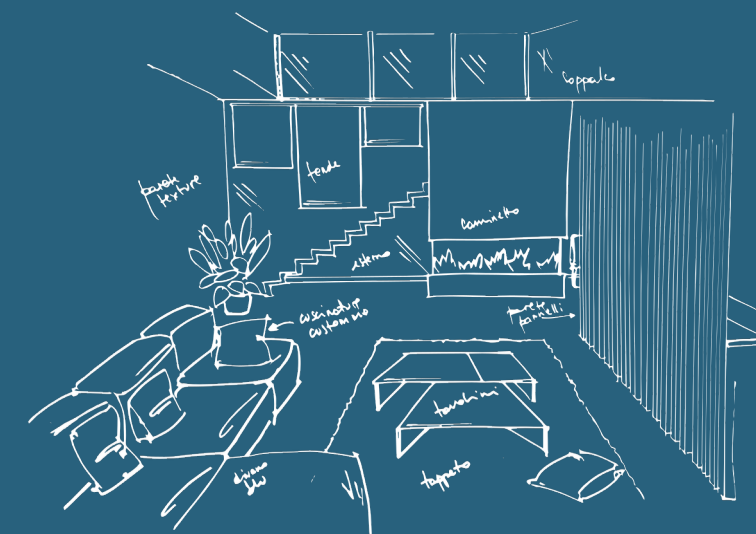

Eleganza e armonia con Custom-Me. L'ambiente living si riveste di un motivo grafico che pervade pareti, tende, tappeti e complementi d'arredo, dando così vita ad un gioco di volumi in cui ogni particolare prende risalto e fa la differenza.

Elegance and harmony with Custom-Me. The living space dresses itself up with a graphic pattern that penetrates walls, curtains, carpets and accessories, creating a game of volumes in which every detail, every single object stands out and makes the difference.

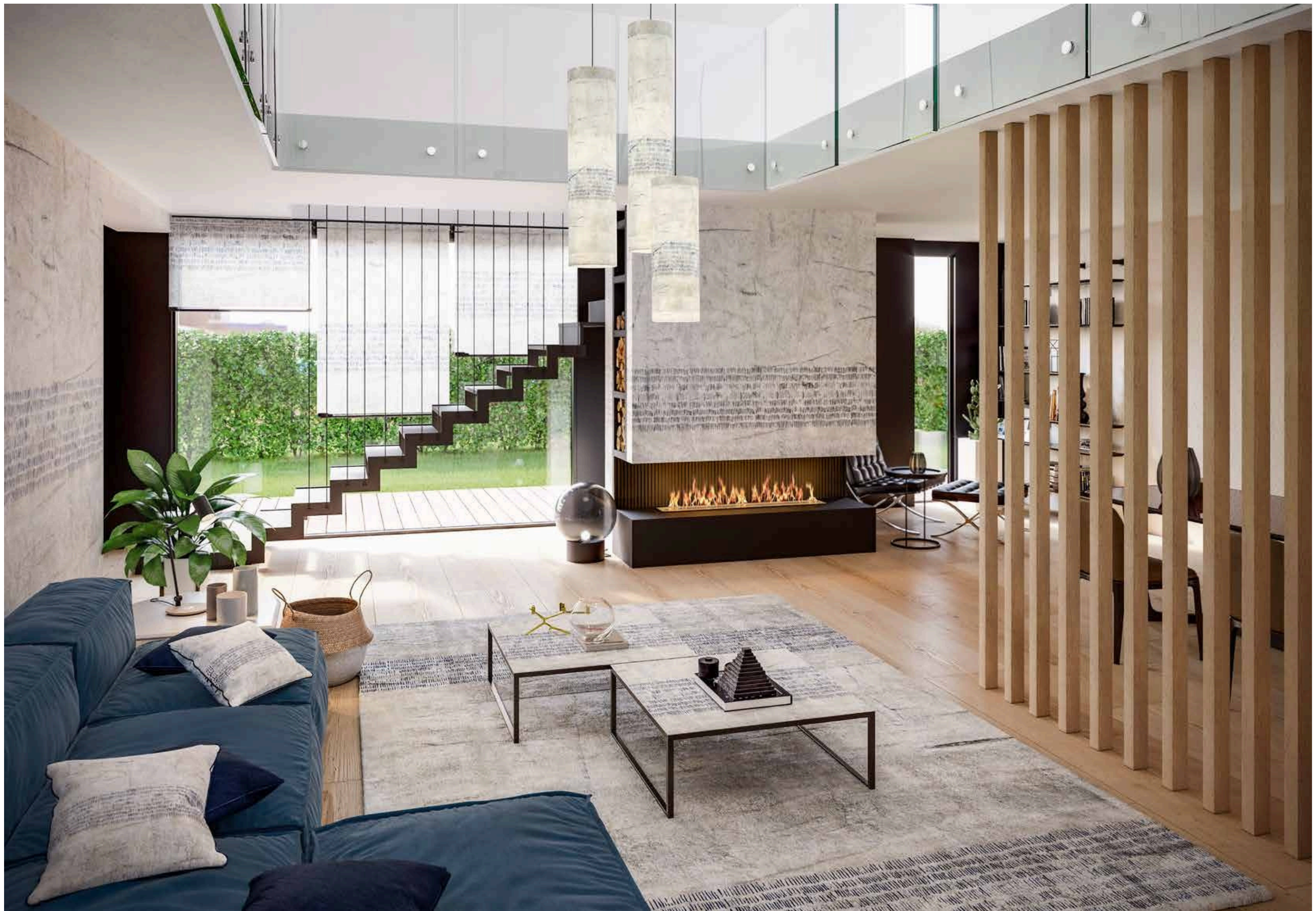

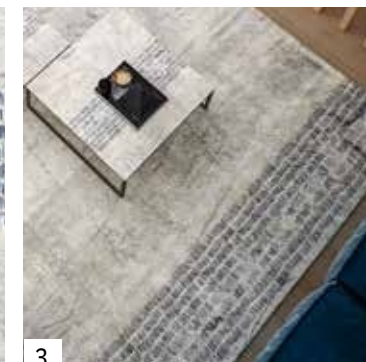
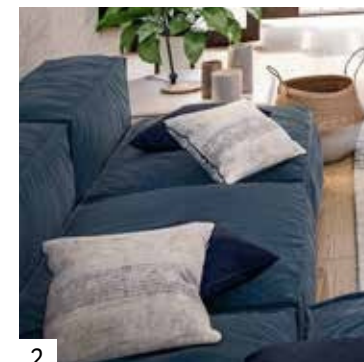
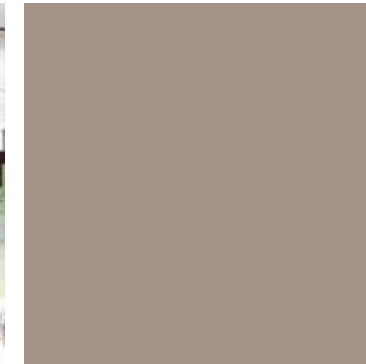

- 1. Cortinas
- 2. Textile
- 3. Moketa carpet
- 4. Beautiful Light



CUSTOMLIVING02

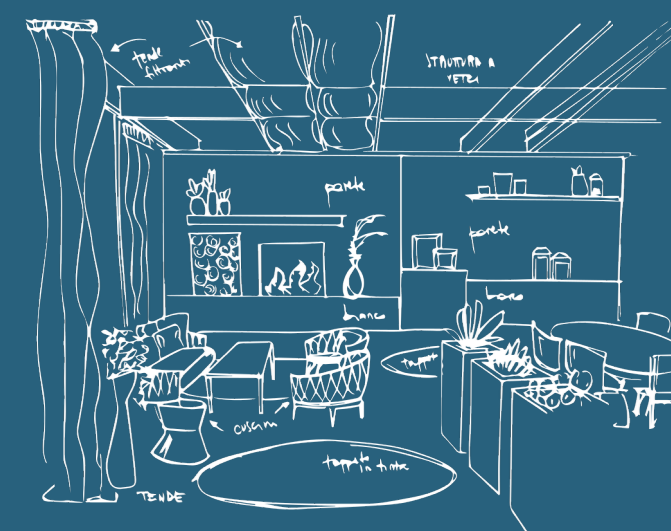

Il progetto Custom-Me permette di rivestire l'ambiente con l'atmosfera desiderata, proprio come la scelta delle tonalità calde o fredde su un quadro. Ecco che il sogno di un living rilassante e immerso nella natura diventa realizzabile giocando con l'utilizzo della grafica che coinvolge, oltre alle pareti, anche tessuti, tende, drappi, cuscini e tappeti.

The Custom-Me project allows to design the entire room with the desired atmosphere, just like the choice of warm or cold tones on a painting. Here the dream of a relaxing living immersed in nature becomes possible by playing with the use of graphics, which involves not only walls, but also curtains, drapes and carpets.





1



2



3



4



- 1. Cortinas
- 2. Cortinas
- 3. Moketa carpet
- 4. Textile



CUSTOMNIGHT01

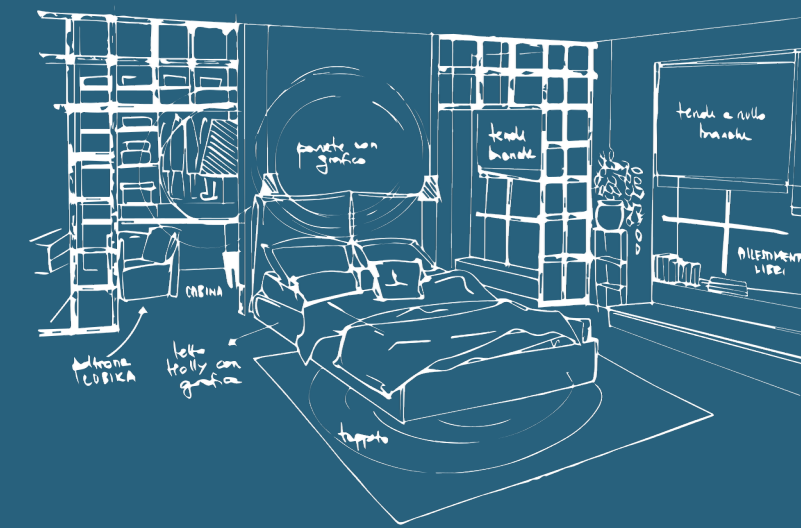

La texture grafica diventa elemento di design anche per la zona notte ricreando atmosfere metropolitane, oniriche, artistiche o naturali in totale armonia con lo stile architettonico e arredativo degli spazi.

The graphic texture becomes a design element also for the sleeping area, recreating metropolitan, dreamlike, artistic or natural atmospheres in total harmony with the architectural and furnishing style of the spaces.



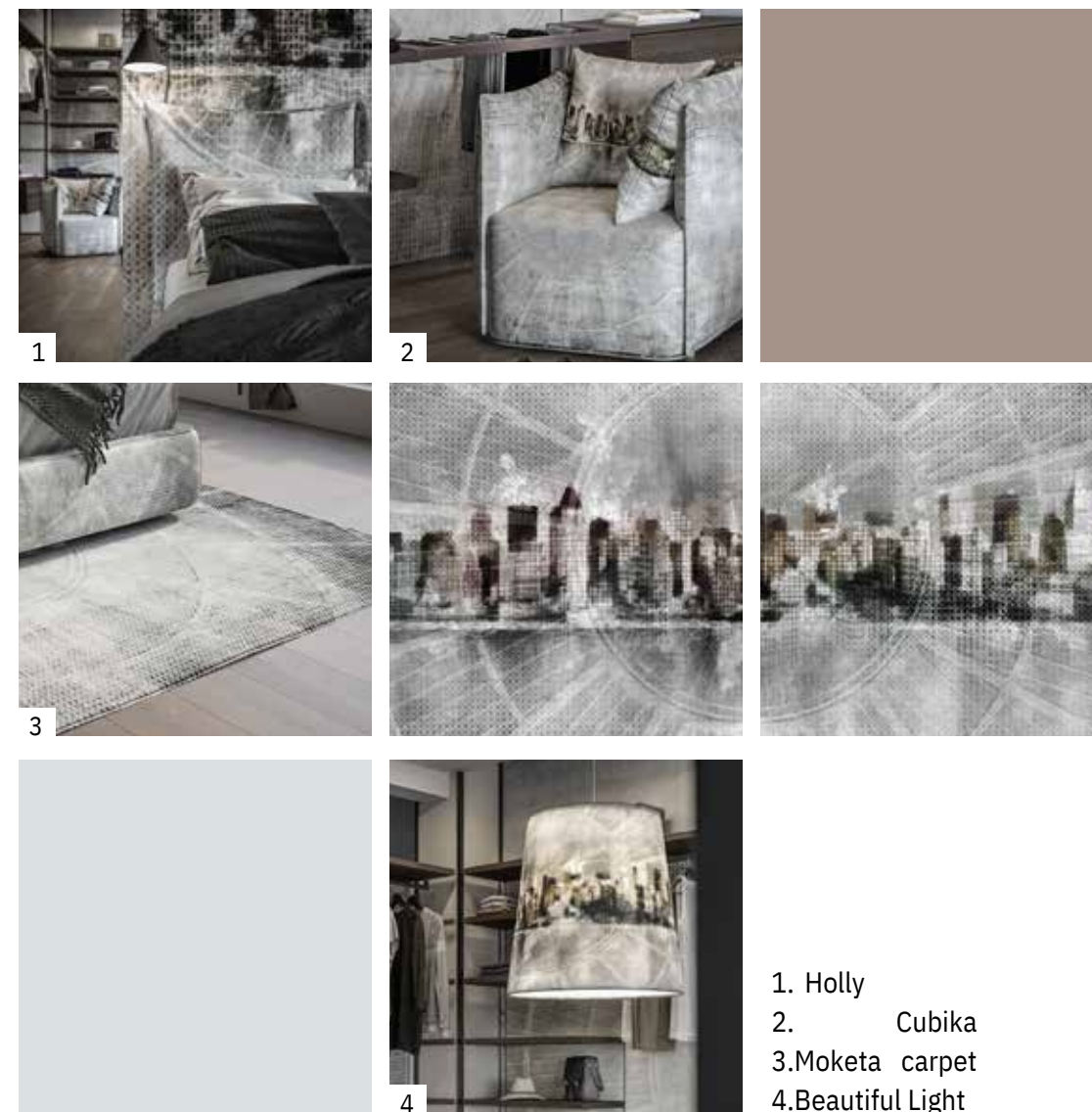

- 1. Holly
- 2. Cubika
- 3. Moketa carpet
- 4. Beautiful Light



CUSTOMNIGHT02



Custom-me trova piena espressione negli ambienti contract valorizzando il singolo contesto con scelte caratterizzanti e d'impatto. Ogni stanza può essere differente a seconda del tema che viene esaltato ai massimi livelli.

Custom-me finds full expression in contract environments by enhancing the individual context with characterizing and impact choices. Each room can be different depending on the theme, which is enhanced at the highest level.





1



2

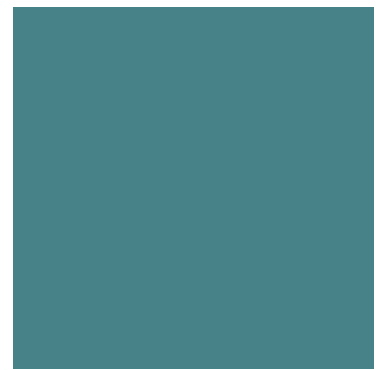

3



4

1. Compo-Bed 2.
Cortinas 3.
Annabel
4. Beautiful Light



CUSTOMMEETING01

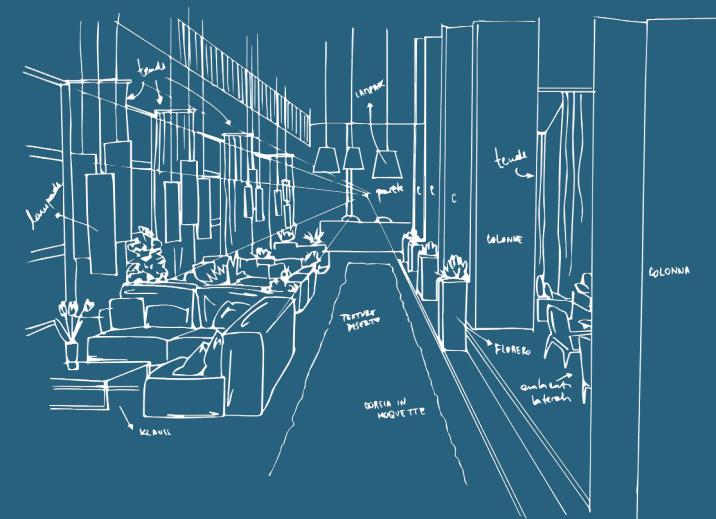

Zone d'attesa e reception, hall alberghiere e aziendali, showroom e zone comuni, anche gli spazi di grandi dimensioni possono essere personalizzati con Custom-Me, creando così ambienti piacevoli e originali nei quali intrattenersi.

Waiting and reception areas, hotel and corporate halls, showrooms and common areas, even large spaces can be customized with Custom-Me, thus creating pleasant and original environments in which to entertain.

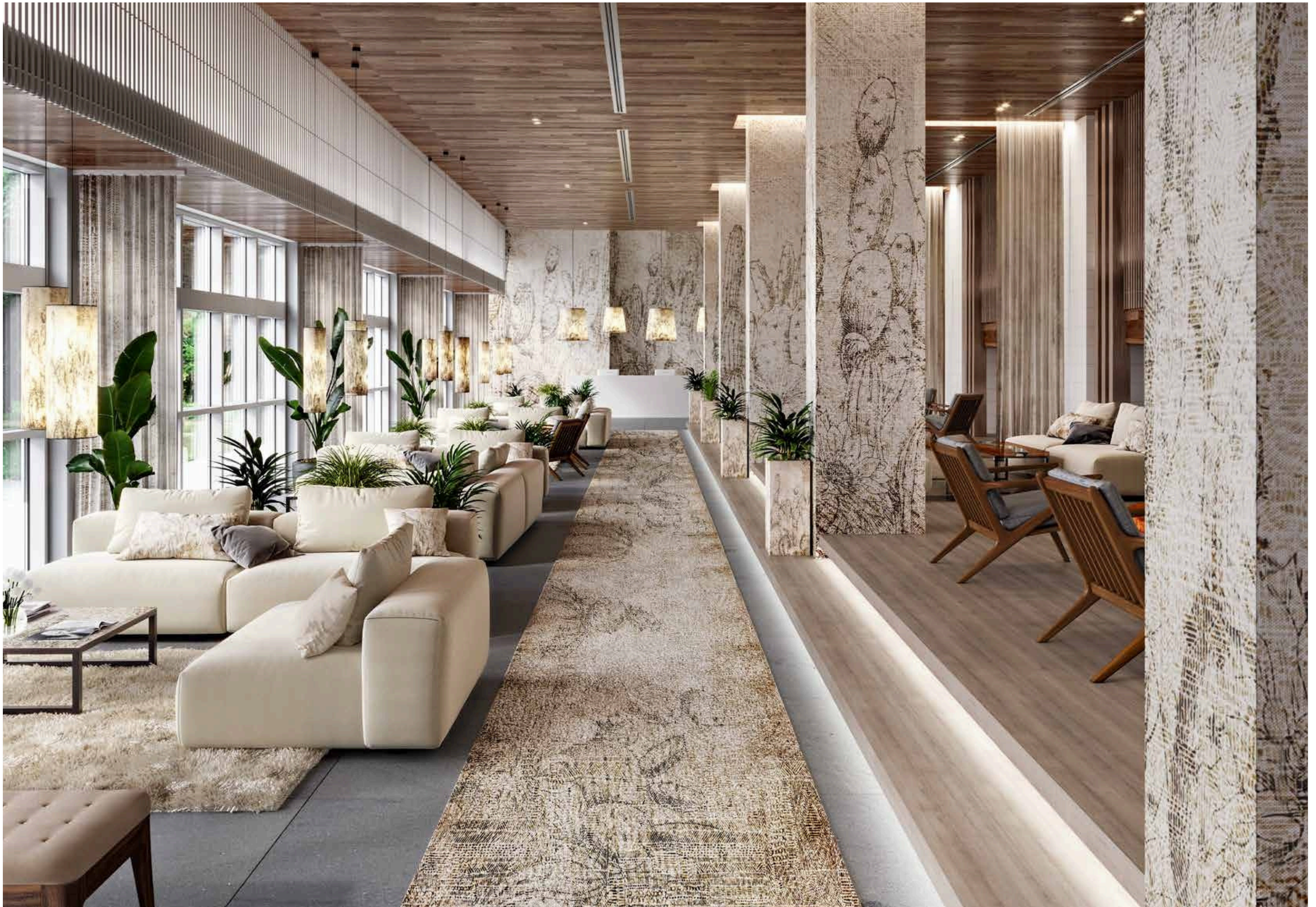

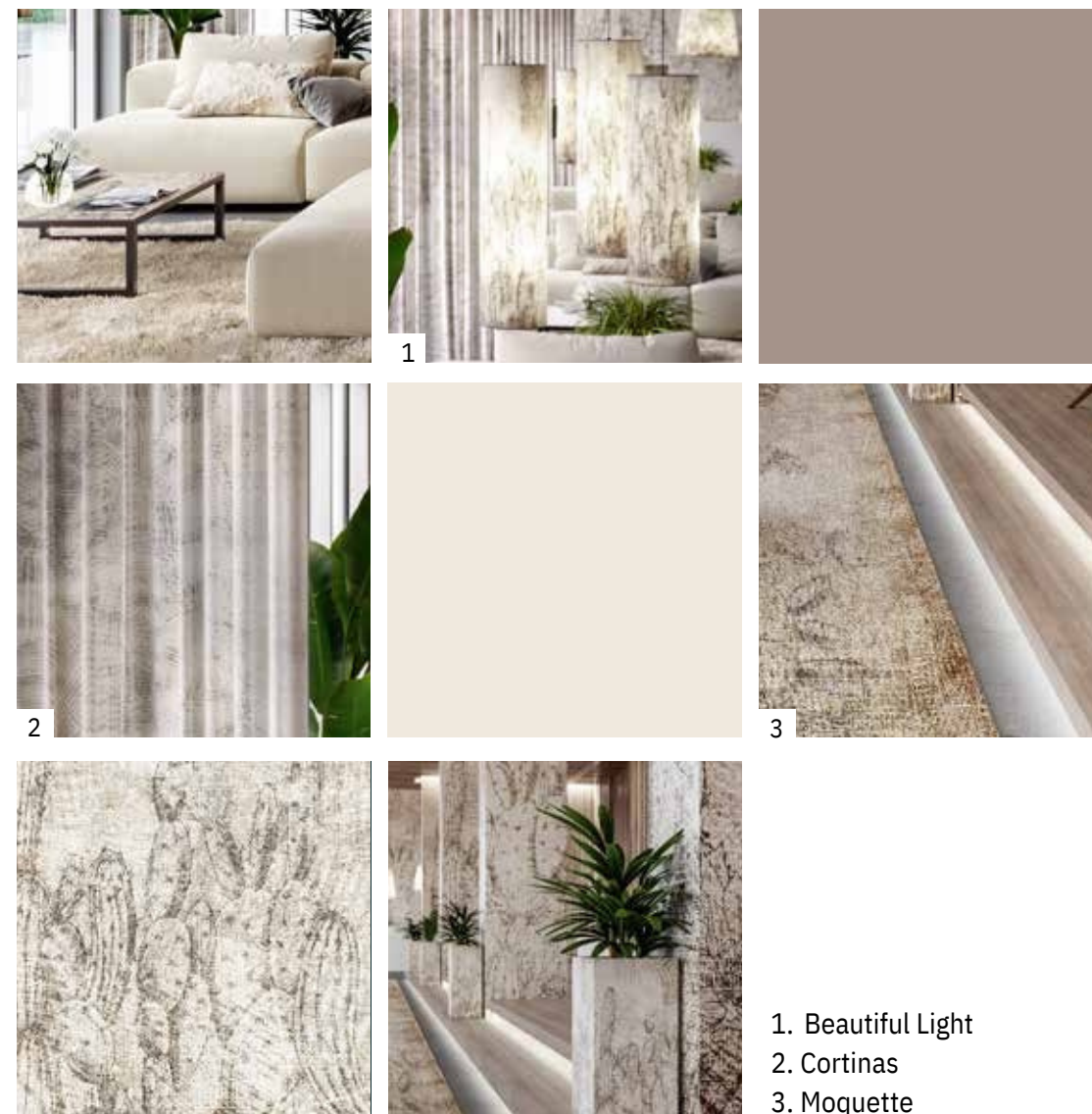

1. Beautiful Light
 2. Cortinas
 3. Moquette





CUSTOMMEETING02

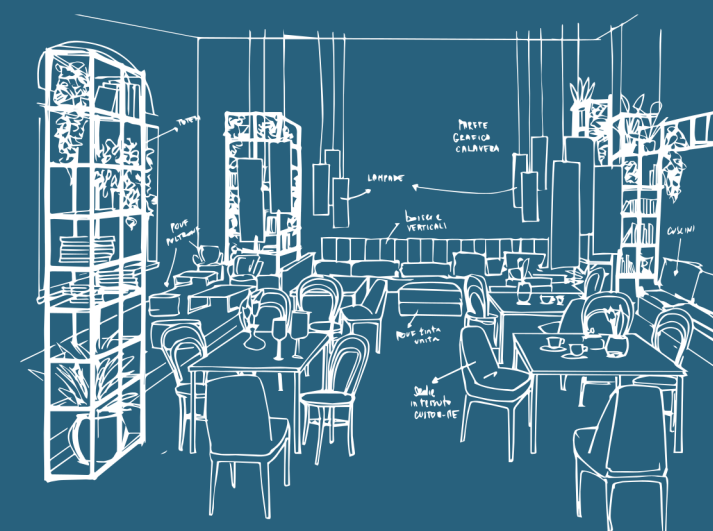

Custom-me è la soluzione ideale per rendere unici gli ambienti pubblici come locali di ristorazione, negozi di abbigliamento, palestre, centri estetici, studi di progettazione e molto altro. La disponibilità di un'ampia scelta di grafiche e stili, unita alla possibilità di personalizzare nel dettaglio ogni elemento consentono infinite strade creative.

Custom-me is the ideal solution to make unique public environments such as restaurants, clothing stores, gyms, beauty centres, design studios and much more. The availability of a wide range of graphics and styles, combined with the possibility to customize each element in detail, allow endless creative paths.



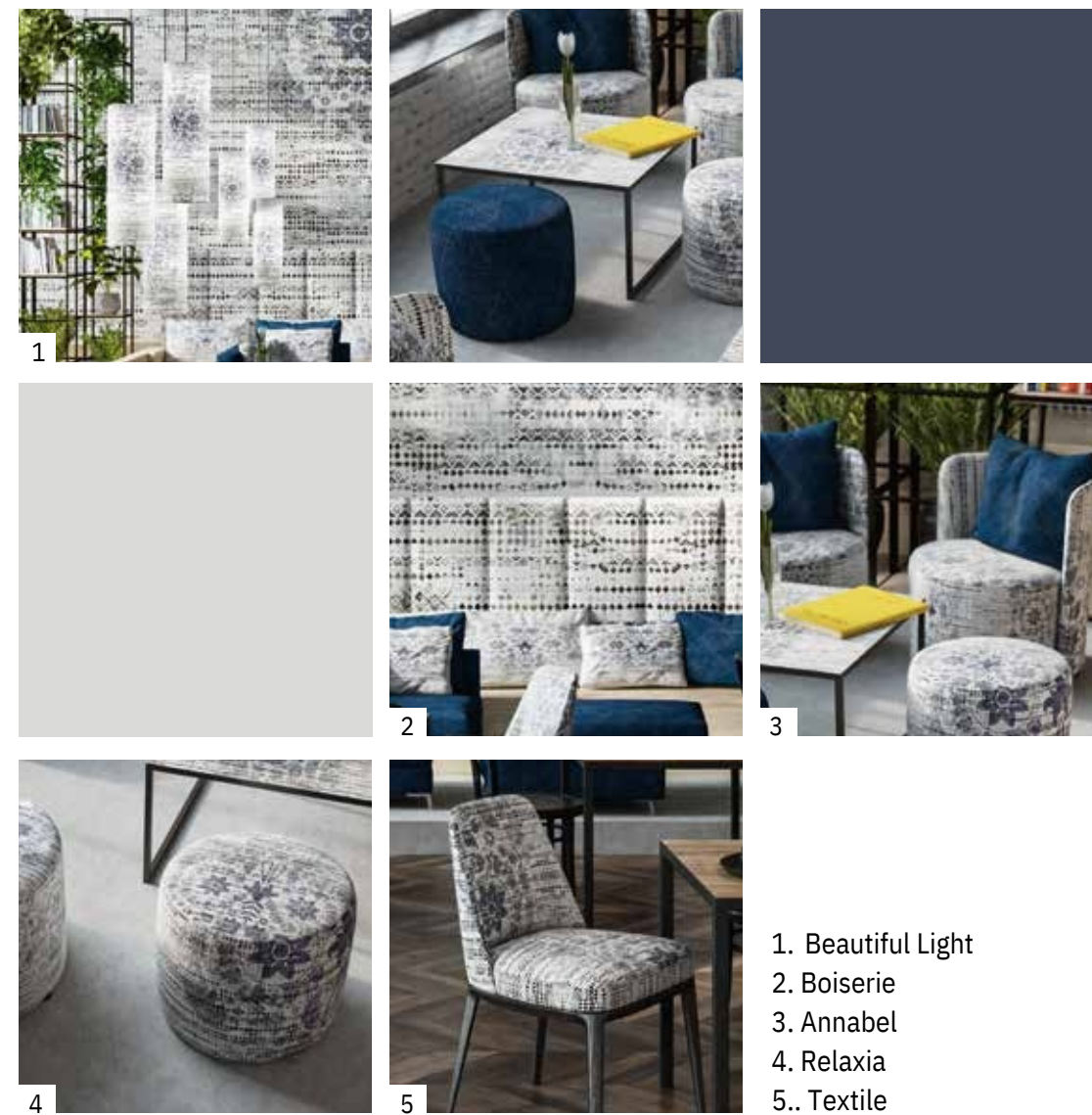

- 1. Beautiful Light
- 2. Boiserie
- 3. Annabel
- 4. Relaxia
- 5.. Textile

Custom-Me

CUSTOM
PRODUCTS

customproducts

| | |
|-----------------------|----|
| HOLLY bed | 49 |
| COMPO-bed | 53 |
| CARPETS | 57 |
| MOQUETTE | 61 |
| CORTINAS curtains | 63 |
| TEXTILE | 67 |
| BEAUTIFUL LIGHT lamps | 71 |
| CUBIKA armchair | 73 |
| ANNABEL armchair | 75 |
| RELAXIA pouf | 77 |

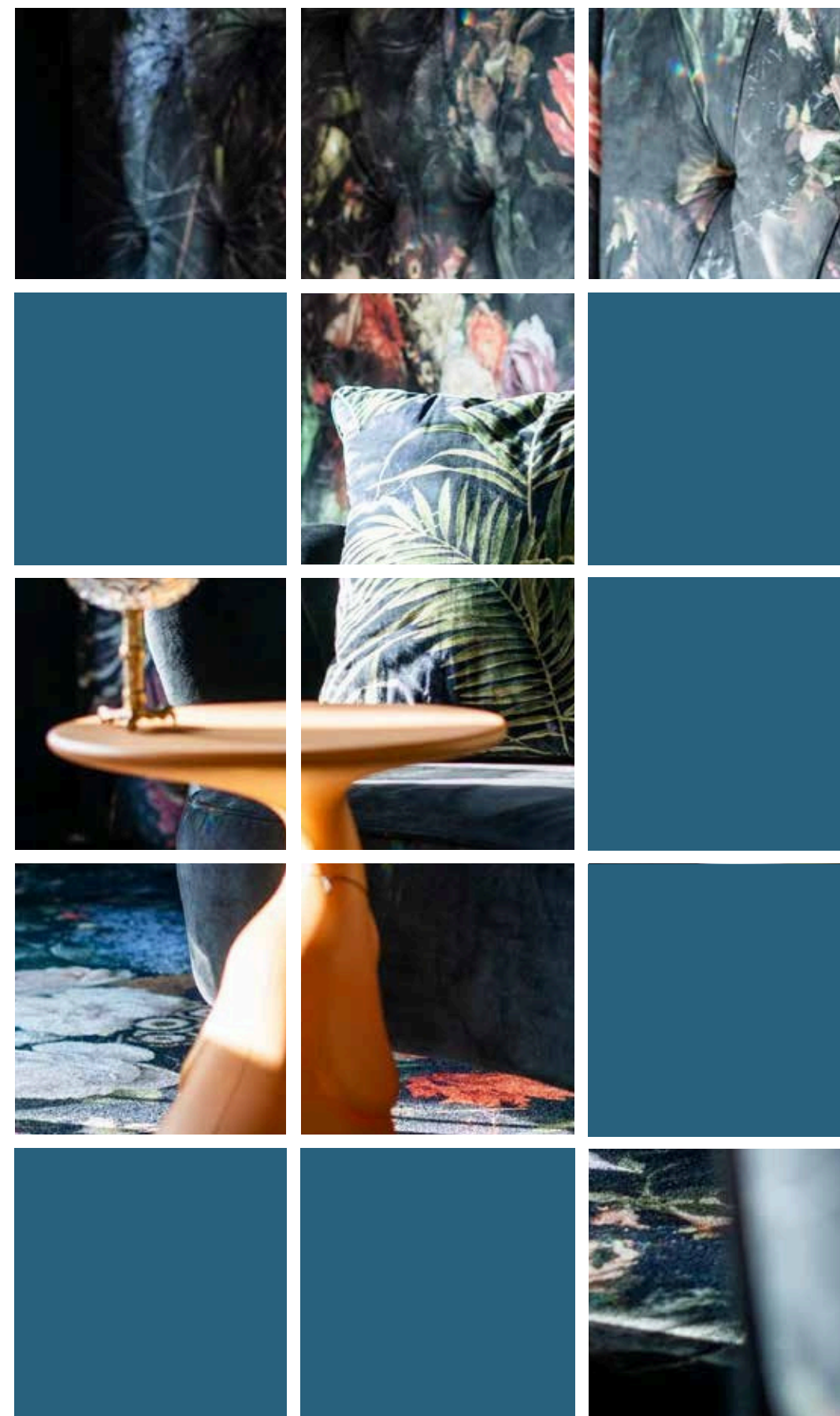



FEBE 01 - Nuances

HOLLY

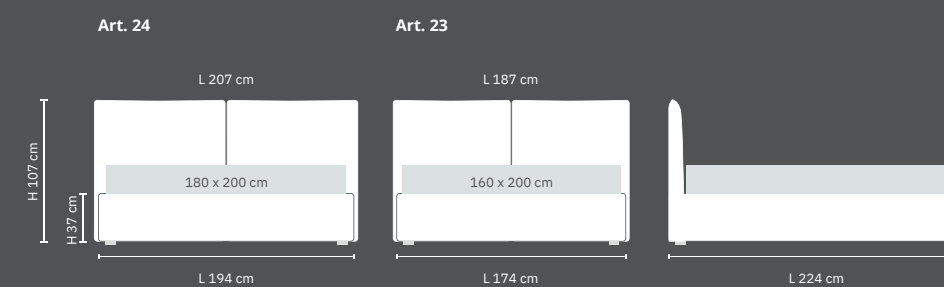

Il particolare che distingue l'ispirazione di questo letto consiste in una doppia cuscinatura sulla testiera, marcata dall'evidente bordo a rilievo. La classica larga base imbottita di Holly permette un rivestimento perfetto con i tessuti personalizzati Custom-me e un morbido contrasto con i cuscini di fondo, anch'essi personalizzati.

The distinctive feature that characterizes the inspiration of this bed consists of a double cushioning on the headboard, marked by the distinctive embossed edge. The classic wide upholstered base by Holly allows a perfect covering with Custom-me customized fabrics and a soft contrast with the back cushions, as well customized.



CHARLOTTE 01 - Audace



NADINE 01 - Artistic

COMPO-BED

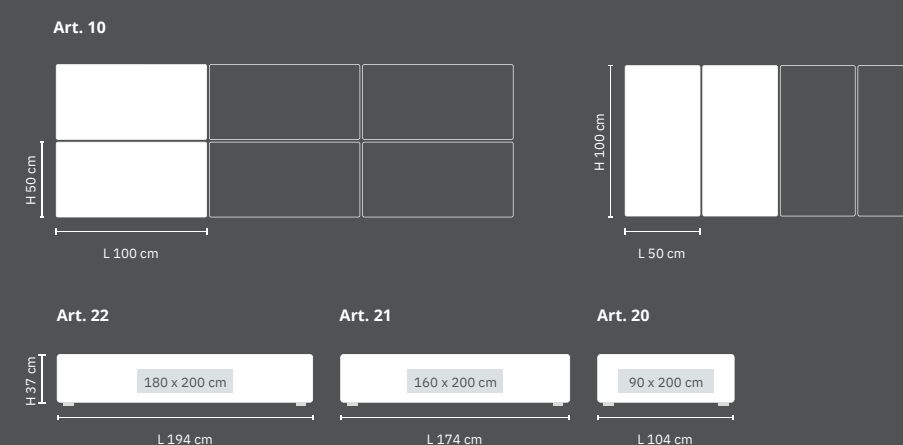

Compo-Bed esprime una progettualità unica nel suo genere. Ad un giroletto con struttura semplice e lineare si abbina la componibilità di una boiserie, da assemblare in orizzontale o in verticale, rivestibile con tessuti stampati con la stessa grafica utilizzata a parete. Una soluzione di continuità di grande effetto.

A bed covered with design, unique in its kind. A bed frame with a simple and linear structure is combined with the modularity of a boiserie, to be assembled horizontally or vertically, to cover with fabrics printed with the same graphics used on the wall. A solution of continuity of great effect.

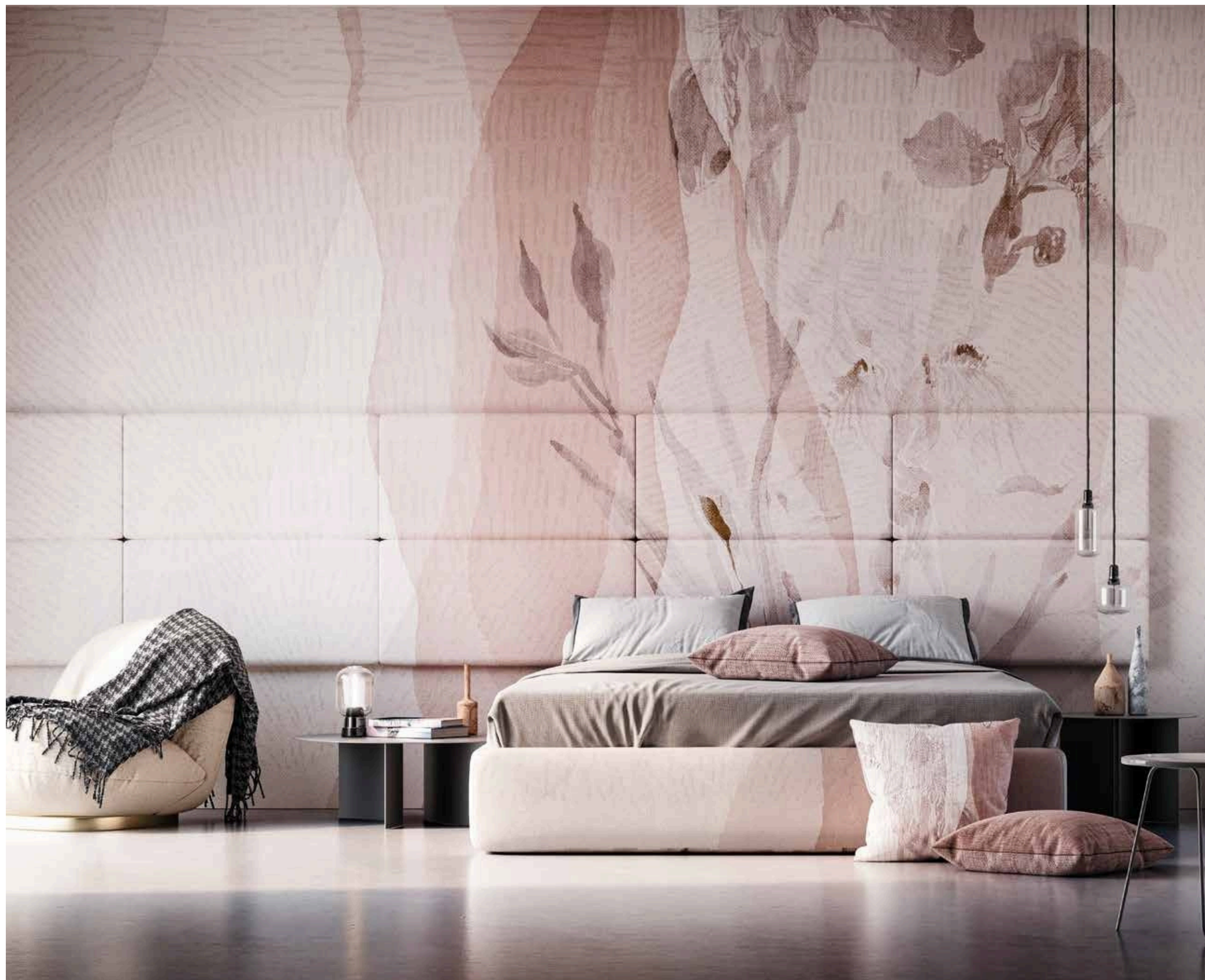

INES 01 - Nuances

CARPETIA



CARPETS



ø 300 cm



ø 250 cm



ø 200 cm



400 x 300 cm



350 x 250 cm



300 x 200 cm



240 x 170 cm

Tappeti per arredare, per delimitare spazi e crearne di nuovi, tappeti per portare anche a terra le grafiche a parete con ricercatezza ed eleganza. Instabilelab arricchisce la sua proposta arredativa con elementi di nuove dimensioni e nuovi materiali: CARPETIA ROYAL, materiali prestigiosi disponibili in 30 grafiche dedicate e MOKETA, il modello versatile e personalizzabile con tutte le grafiche Instabilelab.

Carpets to decorate, to enclose spaces and create new ones, carpets to reproduce graphics on the wall as well as on to the ground with refinement and elegance. Instabilelab enriches its collection with new materials and dimensions. CARPETIA ROYAL, prestigious materials available for 30 dedicated graphics and MOKETA, the versatile and customizable carpet, available for all the graphics of our collection.



ZAIRA 01 - Audace



MOQUETTE

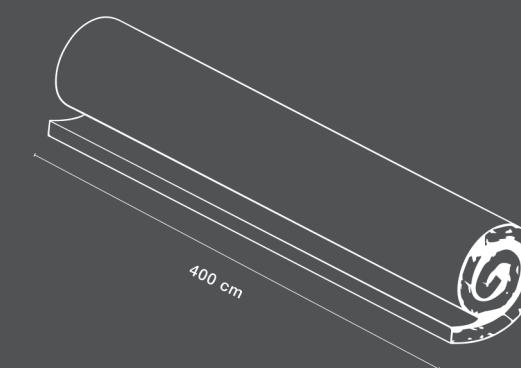

La moquette è il complemento d'arredo da sempre più utilizzato nell'hôtellerie e negli spazi fieristici per le sue caratteristiche di fonoassorbenza e confort.

La personalizzazione con tutte le grafiche in collezione è molto apprezzata dagli interior designer che possono dare così maggiore valore e unicità agli ambienti.

Carpeting is the furnishing accessory increasingly used in the hotel and exhibition spaces for its characteristics of soundproofing and comfort. Its customization is highly appreciated by interior designers who can give greater value and uniqueness to the environments.



CORTINAS



I tendaggi sono un elemento d'arredo di grande importanza. Oltre a decorare, modulano la luce esterna e creano atmosfere differenti di giorno, di sera o con illuminazione artificiale. Instabilelab propone la stampa di tutte le grafiche a collezione su tessuti per tende filtranti o coprenti, a seconda delle esigenze di luce e di arredo.

The curtains are a furnishing element of great importance. As well as decorating they modulate the external light and create different atmospheres, during the day, at night or with artificial lighting. Instabilelab offers the printing of all collection graphics on fabrics for filtering or covering curtains, depending on the light and furnishing needs.



DRAGON TREE 01 - Nuances

TEXTILE

È nei particolari che si fa la differenza. Per questo Instabilelab stampa tutte le grafiche a collezione su una selezione di tessuti a campionario, scelti appositamente per realizzare cuscinate, imbottiti, rivestimenti, tende ottenendo così una personalizzazione totale dell'arredo.

It is in the details that the difference is made. Instabilelab prints all the graphics in the collection on a selection of sample fabrics, specially chosen to create cushions, upholstery, coverings, curtains and thus allow a total customization of the furniture.





FRIDA 01 - Audace



BEAUTIFUL LIGHT

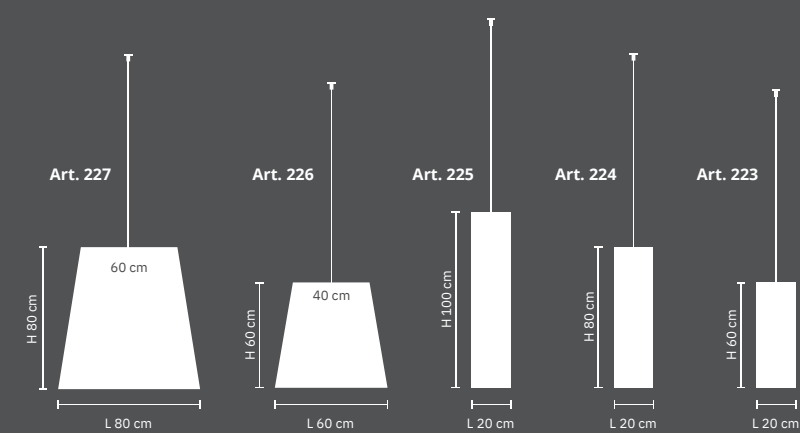

La luce si veste di trame e colori. Proposta in due forme, conica o cilindrica, Beautiful Light può essere inserita singolarmente o a gruppi di elementi per creare movimento ed un effetto scenico di grande stile.

The light is dressed in textures and colors. Proposed in two shapes, conical or cylindrical, Beautiful Light can be inserted individually or in groups of elements to create movement and a scenic effect of great style.



CUBIKA

Art. 148

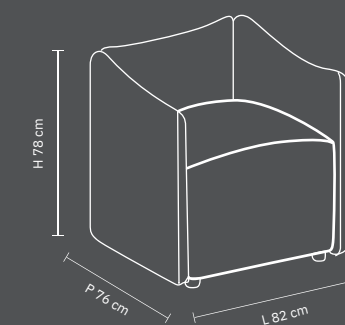

Moderna con il suo profilo squadrato, la nuova poltrona Cubika arreda con eleganza sia lo spazio living, sia la zona notte della casa. La seduta presenta una struttura in legno rivestita in Technoform ed imbottitura in poliuretano indeformabile di diversa densità, per un confort unico.

Modern with its squared profile, the new Cubika armchair elegantly furnishes both the living space and the sleeping area of the house. This design element has a wooden structure covered in Technoform and non-deformable polyurethane padding of different densities, for a unique comfort.

ANNABEL

Art. 149



La solida rotondità di un pouf abbinata all'abbraccio di uno schienale dalla delicata imbottitura, questa è Annabel.

Due volumi che si combinano con semplicità e originalità creando una seduta adatta sia alla zona notte, sia a spazi d'attesa e a zone retail.

The solid roundness of a pouf combined with the embrace of a backrest with delicate padding, this is Annabel.

Two volumes that combine together with simplicity and originality creating a small armchair suitable both for the sleeping area and for waiting or retail areas.



RELAXIA

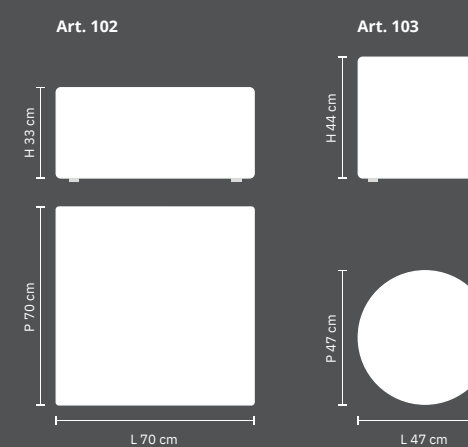

Elementi d'arredo versatili, ideali per creare informali zone conversazione o per completare un contesto living, domestico o contract. I pouf Relaxia hanno forme semplici, ideali per essere personalizzate con tutte le grafiche della collezione. Prodotto 100% manifattura artigianale italiana.

Versatile furnishing elements, ideal to create informal conversation areas or to complete a living context both domestic and contract. Relaxia poufs have simple shapes, ideal to be customized with all the graphics of the collection. Product 100% Italian craftsmanship.